

Bencros BTM Block Fenders, traditionally called M-fenders, are moulded rubber units mostly used on the bows and sterns of tugs, providing robust, heavy-duty protection.

BTM Blocks are also popular for pontoons and RoRo ramp ends. They are mounted via steel pins inserted through the twin holes which allows for easy installation and replacement.

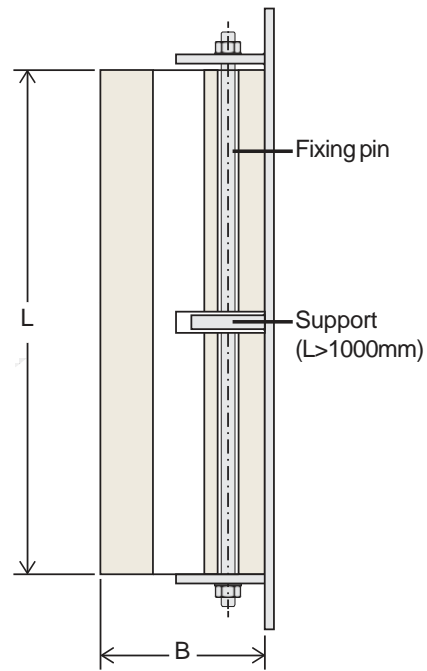
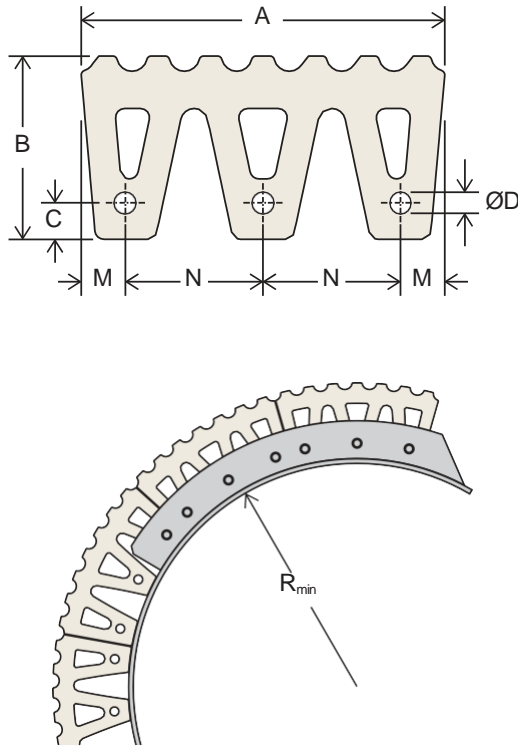

Type	A	B	C	ØD	E	F	ØP	LMAX	Flat Bar	R(min)	Weight
BTM-400	400	200	40	23	50	150	20	2000	100 x 15	450	56
BTM-500	500	250	50	27	60	190	24	2000	125 x 20	550	89
BTM-600	600	300	60	33	70	230	30	2000	150 x 20	650	132

Performance tolerance is $\pm 20\%$.

Reaction is per square metre of flat fender area and for Bencros C1 (standard) rubber grade.

Dimensions are in millimetres.

Weights are in kilogrammes per metre length.

For other sizes, fixing details and custom features, please ask Bencros.

